



EXHIBITIONS, SHOWS AND STANDS

by Mark Coles

Introduction

This article looks at temporary electrical installations associated with exhibitions, shows and stands. Such installations may be installed indoors or outdoors within permanent or temporary structures.

The electrical installation of the building, if any, in which the exhibition, show or stand will take place, will not be considered.

Currently, there is no Part or Section of BS 7671: 2001 (2004) covering exhibitions, shows and stands. Information can be found in IEC 60364-7-711 and HD 60364.7.711 in addition to Guidance Note 7.

It is proposed that a new section, Section 711 - Exhibition, Shows and Stands, will be included in BS 7671: 2008, The 17th Edition of the IEE Wiring Regulations. The DPC of BS 7671: 2008 includes Section 711, however, this is subject to change.

Definitions

The following definitions are extracted from IEC 60364-7-711:

Exhibition

Event intended for the purpose of displaying and/or selling products etc., which can take place in any suitable location, either a room, building or temporary structure display or performance in any suitable location, either a room, building or temporary structure.

Show

Display in any suitable location, either a room, building or temporary structure.

Stand

Area or temporary structure used for display, marketing, sales, etc.

Temporary structure

A unit or a part of a unit including mobile portable units, situated indoors or outdoors, designed and intended to be assembled and dismantled.

Temporary electrical installation

Electrical installation erected and dismantled at the same time as the

stand or the display with which it is associated.

Origin of the temporary electrical installation

Point on the permanent installation or other source of supply from which electrical energy is delivered.

Risks and hazards

The particular risks associated with exhibitions, shows and stands are those of electric shock and fire due to the temporary nature of the installation, the lack of permanent structures, severe mechanical stresses and access to the general public.

Note that BS 7671 will apply generally but due to these increased risks, additional measures are recommended.

Assessment of general characteristics

The nominal supply voltage of temporary electrical installations in exhibitions, shows and stands should not exceed 230/400 v a.c. As for d.c., the supply should not exceed 500 v d.c. between any conductors.

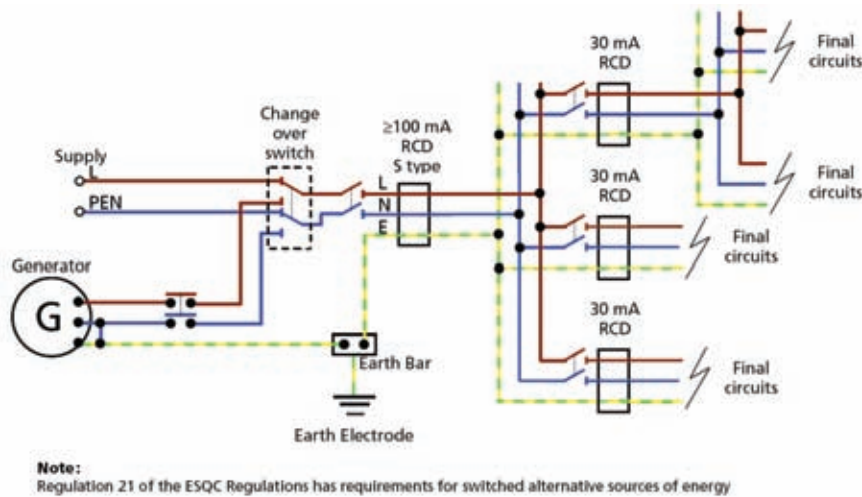

Fig 2: Exhibition /show distribution with stand-by generator

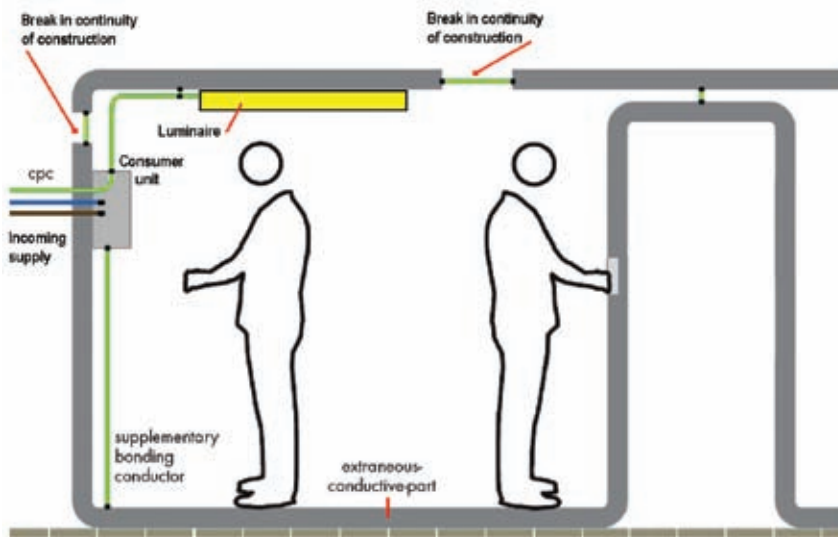

Fig 3: Construction does not ensure continuity alone

System types

The standards require that where the system earthing is TN it should be TN-S other wise a TT earthing system should be used.

Importantly, the following systems are NOT permitted:

TN-C

Regulation 8(4) of the Electricity Safety, Quality and Continuity

Regulations 2002 prevents the use of combined neutral and earth conductors in any part of a consumer's installation.

TN-C-S

Because of the practical difficulties of bonding all accessible extraneous-conductive-parts, a TN-C-S (PME) system is not appropriate for temporary and/or outdoor installations.

Generators

Installations incorporating generator sets should comply with Section 551 of BS 7671.

Where a generator is used to supply the temporary installation using a TN or TT system, it must be ensured that the installation is earthed, preferably by separate earth electrodes. BS 7430, Code of practice for earthing, states that for independent earth electrodes associated with the local earthing of the star point of generating plant, it is recommended that the earth electrode resistance should not exceed 20 Ω .

For TN systems all exposed-conductive-parts should be bonded back to the generator. The neutral conductor and/or star point of the generator should be connected to the exposed-conductive-parts of the generator and reference earthed; see figure 2.

Protection against electric shock

Protection against direct contact by means of obstacles and protection against indirect contact by non-conducting location placing out of reach should not be used.

Protective equipotential bonding

Structural metallic parts which are accessible from within the stand shall be bonded to the main earthing terminal and in more than one place if the type of construction does not ensure continuity; see figure 3.

The CSA should be not less than 4 mm² copper. Guidance Note 3, Inspection and Testing, published by the IEE, advises that supplementary equipotential bonding conductors should have a resistance of 0.05 Ω , or less.

Residual current devices

Cables supplying temporary structures should be protected at their origin by an RCD of a residual current rating no greater than 300 mA.

These devices should be of the

S-type for discrimination with RCDs protecting final circuits downstream, see figure 4.

All circuits for socket-outlets rated up to 32 A and all final circuits other than for emergency lighting should be protected by an RCD with a rated residual operating current not exceeding 30 mA.

Cables supplying temporary structures should be protected at their origin by an RCD of a residual current rating no greater than 300 mA.

These devices should be of the S-type for discrimination with RCDs protecting final circuits downstream, see figure 4.

All circuits for socket-outlets rated up to 32 A and all final circuits other than for emergency lighting should be protected by an RCD with a rated residual operating current not exceeding 30 mA.

Isolation

Every separate temporary structure, such as a vehicle, a stand or a unit, intended to be occupied by one specific user should be provided with their own readily accessible and properly identifiable means of isolation; see figure 5.

Further, each distribution circuit supplying outdoor installations should be provided with its own readily accessible and properly identifiable means of isolation; examples of such devices are shown in figures 6, 7, and 8.

Protection against fire

A motor which is automatically or remotely controlled and which is not continually supervised should be fitted with a manual reset protective device against excess temperature.

Lighting equipment such as incandescent lamps, spotlights, small projectors including all other equipment or appliances with high temperature surfaces shall be suitably located, guarded and installed.

All such equipment shall be arranged well away from combustible



Fig 4: S-Type RCD



Fig 5: Identifiable means of isolation



Fig 6: RCD



Fig 7: MCB



Fig 8: Plug and socket-outlet

material to prevent contact.

Showcases and signs shall be constructed of material having an adequate heat resistance, mechanical strength, electrical insulation and ventilation, taking into account the combustibility of exhibits in relation to the heat generation.

Stand installations containing a concentration of electrical apparatus, lighting fittings or lamps liable to generate excessive heat shall not be installed unless adequate ventilation provisions are made, e.g. well ventilated ceiling constructed of incombustible material. In all cases, the manufacturers' instructions shall be followed.

Wiring systems

Armoured cables or cables protected against mechanical damage should be used wherever there is a risk of

mechanical damage. Wiring cables should be copper and have a minimum cross-sectional area of 1.5 mm², and they should comply with BS 6007 or as appropriate.

Flexible cords should not be laid in areas accessible to the public unless they are protected against mechanical damage.

Wiring systems - fire

Where no fire alarm system is installed in a building used for exhibitions, etc., cable systems should be either be flame retardant to BS EN 60332-1 or BS EN 60332-3 and low smoke to BS EN 61034 or single or multicore unarmoured cables enclosed in metallic or non-metallic conduit or trunking, providing fire protection in accordance with BS EN 50085 or BS EN 50086 and providing a degree of protection of at least IP4X.



Wiring systems – electrical connections

Joints should not be made in cables except where necessary as a connection into a circuit. Where joints are made, these should be either using connectors in accordance with the BS 7671, the manufacturer's instructions or the connection should be made in an enclosure with a degree of protection of at least IP4X or IPXXD. Where strain can be transmitted to terminals the connection should incorporate cable anchorage(s).

Lighting installations

Luminaires mounted below 2.5 m (arm's reach) from floor level or otherwise accessible to accidental contact should be firmly and adequately fixed and so sited or guarded as to prevent risk of injury to persons or ignition of materials.

In the case of outdoor lighting installations, HD 384.7.714 applies and

a degree of protection of at least IP33* may be required. The rating IP33 means (first digit) protection against solid foreign objects of 2.5 mm diameter and greater and (second digit) protected against water spraying at an angle up to 60° on either side of the vertical.

Lighting installations – electrical discharge lamp installations

Installations of any luminous tube sign or lamp as an illuminated unit on a stand, or as an exhibit with nominal power supply voltage higher than 230/400 v a.c. should be installed out of arm's reach or should be adequately protected to reduce the risk of injury to persons. The fascia or stand fitting material behind luminous tube signs or lamps should be non-ignitable and protected as required by national standards. Controlgear with output voltages higher than 230/400 v a.c. should be mounted on non-ignitable material.

A separate circuit should be used to supply such signs, lamps or exhibits, which should be controlled by an emergency switch. The switch should be easily visible, accessible and marked in accordance with the requirements of the local authority.

Verification

The temporary electrical installations of exhibitions, shows and stands should be tested on site in accordance with Part 7 of BS 7671 after each assembly on site. Users should check the installation for damage on a daily basis. ■

Bibliography and further reading

Further information is available from the following sources and publications:

- BS 7671: 2001 (2004) Requirements for electrical installations
- Guidance Note 3 – Inspection and Testing, Inc AMD No.2 : 2004, IEE Publications
- Guidance Note 7 – Special Locations, Inc AMD No.2 : 2004, IEE Publications
- BS 7430: 1998 Code of practice for earthing
- IEC 60364-7-711 available from www.iec.ch
- HD 60364-7-711 available from www.cenelec.org
- Electricity Safety, Quality and Continuity Regulations 2002
- HSE Guidance Notes:
 - Health and Safety at Work etc Act 1974 HMSO, ISBN 010 543774 3
 - Electricity at Work Regulations 1989, SI 1989 No 635 HMSO, ISBN 0 11 096635 X
 - Memorandum of guidance on the Electricity at Work Regulations 1989, HS(R) 25 HMSO ISBN 011 883963 2

Thanks for the images used:

Clare Barnes (IET Events)
CEE Norm UK Ltd
MK Electric
www.tlc-direct.co.uk